

LANCE AND FORM DOUBLE BRIDGE (CARD GUIDE)

TOOL CODE FB

22

ORDERING SPECIFICATIONS

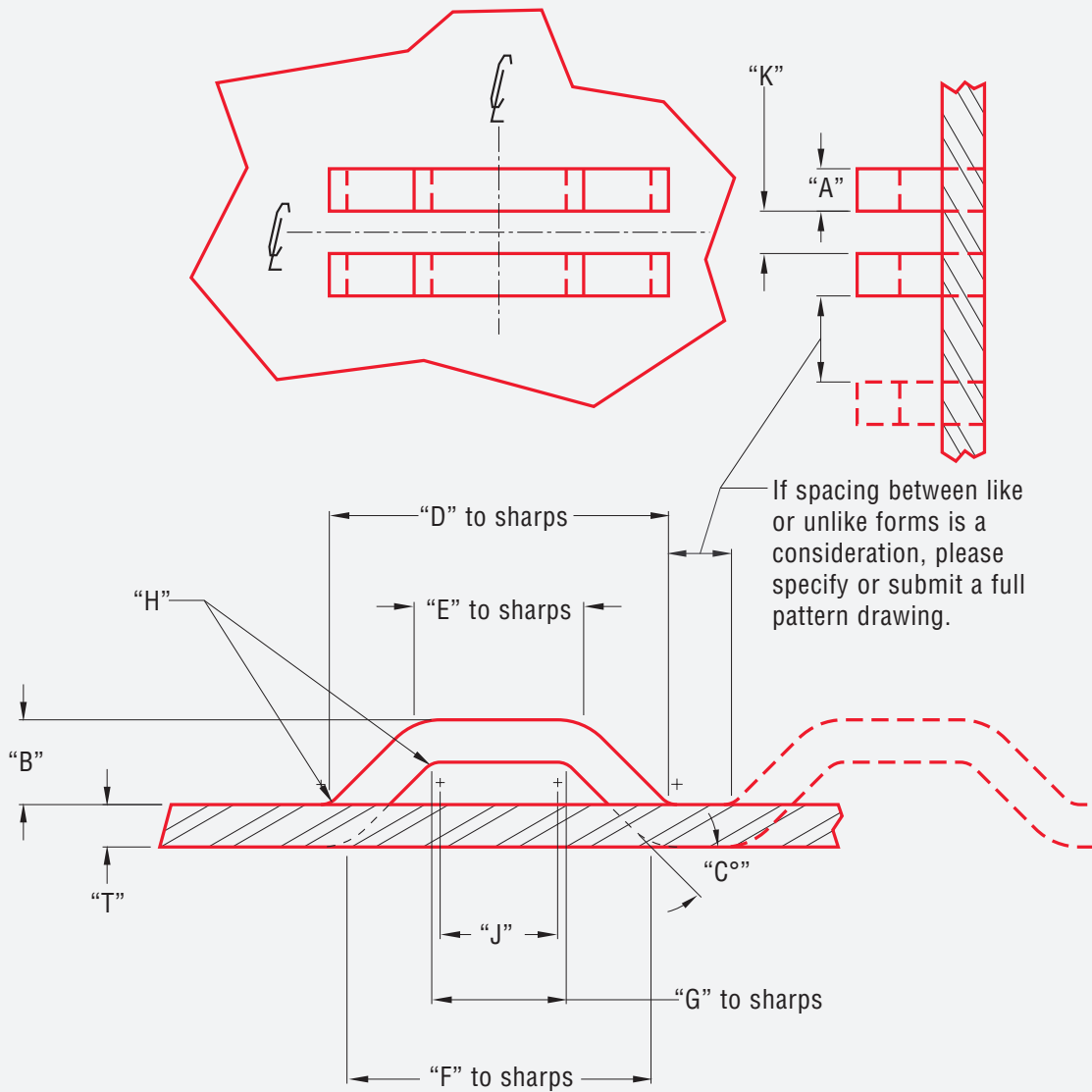

TOOL INFORMATION

Not all of the dimensions shown below are required. Fill in the critical dimensions and a Mate representative will contact you if more information is required.

A _____ F _____
 B _____ G _____
 C° _____ H _____
 D _____ J _____
 E _____ K _____

GENERAL INFORMATION

Material Type _____
 Material Thickness "T" _____
 Machine Type _____
 Tooling Style _____
 Tooling Station _____
 Dimensions filled in by _____
 Approved By _____

° indicates DEGREES



Holland Precision Tooling BV
 Amsterdamsestraatweg 33 - 1411 AW Naarden
 Tel.: 035 - 539 90 90 - info@hptooling.nl

